

# ICC Model VIC

## SINGLE WALL SPECIAL GAS VENT

### INSTALLATION AND MAINTENANCE INSTRUCTIONS

The ICC Model VIC is a listed venting system designed for venting commercial and industrial appliances, condensing appliances, category I, II, III, IV appliances.

For use on positive, neutral and negative pressures up to 15" w.c. (3.75 kPa.)

Sizes: 3" (76mm) to 24" (610mm) diameters

#### WARNING

- A major cause of vent related fires is failure to maintain required clearances (air space) to combustible materials. It is of utmost importance that this venting system be installed only in accordance with these instructions. Do not fill the air space with insulating material.
- Contact local building or fire officials about restrictions and installation inspection in your area.

Do not begin installing the ICC Model VIC venting system until you have carefully read the appliance and vent system installation instructions.

Use only ICC Model VIC components. Failure to do so will void the certification and warranty of the product.

Keep these installation and operating instructions in a safe location for future reference.

- Examine all components for possible shipping damage prior to installation.
- Proper joint assembly is essential for a safe installation.
- Follow these instructions exactly as written.
- Check tightness of joints upon completion of assembly.
- This venting system must be free to expand and contract.
- This venting system must be supported in accordance with these instructions.
- Check for unrestricted vent movement through walls, ceilings, and roof penetrations.
- Different Manufacturers Have Different Joint Systems and Adhesives.
- Do Not Mix Pipe, Fittings, or Joining Methods from Different Manufacturers.

Tested and listed to:  
UL 1738 / ULC S636  
by Underwriters Laboratories, Inc (Listing # MH46076)



ICC INDUSTRIAL CHIMNEY COMPANY INC.  
400 J.F. Kennedy, St. Jérôme  
Québec, Canada, J7Y 4B7  
Tel.: (450) 565-6336  
Fax: (450) 565-6519  
[www.icc-rsf.com](http://www.icc-rsf.com)

# TABLE OF CONTENTS

Model VIC Technical Specifications..... 2  
 Operation and Maintenance..... 3  
 General Installation Notes..... 3  
 Planning your Installation..... 3  
 Assembling Notes..... 4  
 Horizontal through the wall installation..... 6  
 Condensate Drains..... 8  
 Vertical interior installation..... 9  
 Vertical exterior installation..... 12  
 Base Support..... 13  
 Wall Support..... 13  
 Horizontal Band..... 14  
 Guy Band..... 14  
 Horizontal Termination location..... 15  
 Model VIC Single Wall - Parts List..... 16  
 WARRANTY..... 17

## Model VIC Technical Specifications

### Material

Model VIC single wall vent is constructed of either stainless steel grade AL29-4C or 444. The formed gasket is made of high temperature silicone.

### Weight / Thickness

		3"	4"	5"	6"	7"	8"	9"	10"	12"	14"	16"	18"	20"	22"	24"
Thickness (inch)	AL29-4C	0.018"											0.025"			
	444	0.018"														
Weight (lb/ft)	AL29-4C	0.7	0.8	1.0	1.2	1.4	1.6	1.8	2.0	2.4	3.8	4.4	4.9	5.5	6.0	6.6
	444															

### Clearance to Combustibles

Diameter	Maximum Appliance / Vent Rating	Fully Enclosed		Unenclosed		
		Vertical	Horizontal	Vertical*	Horizontal**	
3-5"	400 °F	3"	n/a	1"	1"	
	480 °F	4"				
	550 °F	6"				
6" - 10"	300 °F	n/a		n/a	1"	1"
6" - 12"	550 °F				2"	2"
14"					3"	3"
16" - 20"			4"		4"	
22" - 24"			4"		5"	

\* Enclosed on 3 sides.

\*\* Enclosed on the ceiling and one side wall.

## Operation and Maintenance

KEEP YOUR VENT CLEAN. Your vent system should be examined annually by a qualified service company for the presence of soot or debris. Any accumulation should be removed. Also, the vent system should be inspected periodically for the following:

1. Any leakage of condensate or combustion by-product at joints should be removed.
2. A defective drain trap loop should be repaired to prevent any leakage of exhaust gases inside the building area.
3. Any sign of corrosion.

## General Installation Notes

1. Model VIC is to be installed in accordance with these installation instructions and with those of the appliance manufacturer.
2. Installation is to be in accordance with local building code requirements and National Codes.
3. Size the vent in accordance with the appliance manufacturer's instructions. ICC will calculate correct vent sizing on request.
4. Make sure you read the appliance installation instructions for vent limitations such as maximum horizontal length, maximum number of elbows, total vent height, common venting options, and other limitations that may affect the design and installation of this vent.
5. **DO NOT** connect a natural draft appliance to a common venting system deserving Cat. II, III or IV appliances.
6. Check the joints and seams for gas tightness when using the venting system with a Category III or IV appliance.
7. The venting system **SHALL NOT** be routed into, through, or within any other vent, such as an existing masonry or factory-built chimney flue. Exception: A masonry chimney flue may be used to route Model VIC if no other appliance is vented into the same masonry chimney flue.
8. Model VIC single wall vent can be used with double wall vent within the same installation as long as proper clearances are maintained.
9. The maximum height of un-guyed vent above the roof is 5'.
10. The vent shall extend at least 3' above its point of penetration with the roof and at least 2' higher than any wall, roof or adjacent building within 10' of it.
11. **DO NOT FILL THE AIR SPACE** around the vent with insulation or any other material.
12. **Do not allow sawdust or construction debris** to accumulate around the vent. Clean all areas surrounding the vent before closing up any enclosed areas.
13. Except for installation in single or double family dwellings, a venting system that extends through any zone above the zone which the connected appliance is located shall be provided with an enclosure having a fire resistance rating equal to or greater than that of the floor or roof assemblies through which it passes.
14. Enclosure of exterior mounted venting systems below the roof line is recommended to limit condensation.
15. When required, a drain fitting should be located as close as possible to the appliance flue outlet.
16. **A pitch of at least ¼" to the foot or 2° must be maintained on horizontal run to prevent the accumulation of corrosive condensate.**

## Planning your Installation

Prior to starting your installation, we suggest you take the following into consideration:

1. Check the appliance manufacturer's installation instructions to see all possible vent configurations.
2. Review all your options for the appliance location and also venting configuration. Try to minimize the alteration and reframing of structural components of the building (wall studs, water pipes, electrical wiring, ceiling joists, roof rafters, etc.). It may be easier to change the location of your appliance than to modify the building structure.
3. Use only Model VIC listed components. Do not use damaged parts.
4. The horizontal vent termination on the exterior must be located in accordance with Codes and Regulations.
5. Any penetrations of ceilings, floors, or walls must be properly fire-stopped.
6. Contact your local building authority and/or fire officials for permits, restrictions and installation inspections. You may also wish to contact your building insurance representative.

## Tool checklist

Tools and equipment you may need for your installation.

- |                  |                |                             |                |
|------------------|----------------|-----------------------------|----------------|
| - Eye protection | - Stud sensor  | - Keyhole saw               | - Hammer       |
| - Gloves         | - Square       | - Ladder                    | - Screwdrivers |
| - Tape measure   | - Circular saw | - Level                     | - Screws       |
| - Extension cord | - Hand saw     | - Pliers                    | - Plumb Bob    |
| - Marking pencil | - Drill        | - Caulking gun              | - Cold chisel  |
| - Nails          | - Drill bits   | - Hi Temp. Silicone sealant |                |

## Rules of Safety

1. Wear gloves when handling metal parts with sharp edges.
2. Wear safety glasses.
3. Electrical tools must be grounded.
4. If a ladder is required, it must be in good condition, installed on a firm surface, and leveled.
5. When cutting a wall, floor or ceiling, be careful not to damage wiring, gas or water pipes. If these elements need to be relocated, work should be done by a qualified person.

## Assembling Notes

### Use of sealant

The Model VIC vent has a factory installed high temperature gasket that will make a sealed connection. It is not required to apply sealant on any lengths or fittings. The only exception is the adjustable length. The adjustable length must be sealed with a factory supplied high temperature sealant (X-TRASIL #4706). Allow the sealant to cure for 24 hours before operating the appliance.

If the factory installed gasket is damaged in the field you can seal the joint with the high temperature sealant. Follow the same procedure as for the adjustable length.

### Joint connection

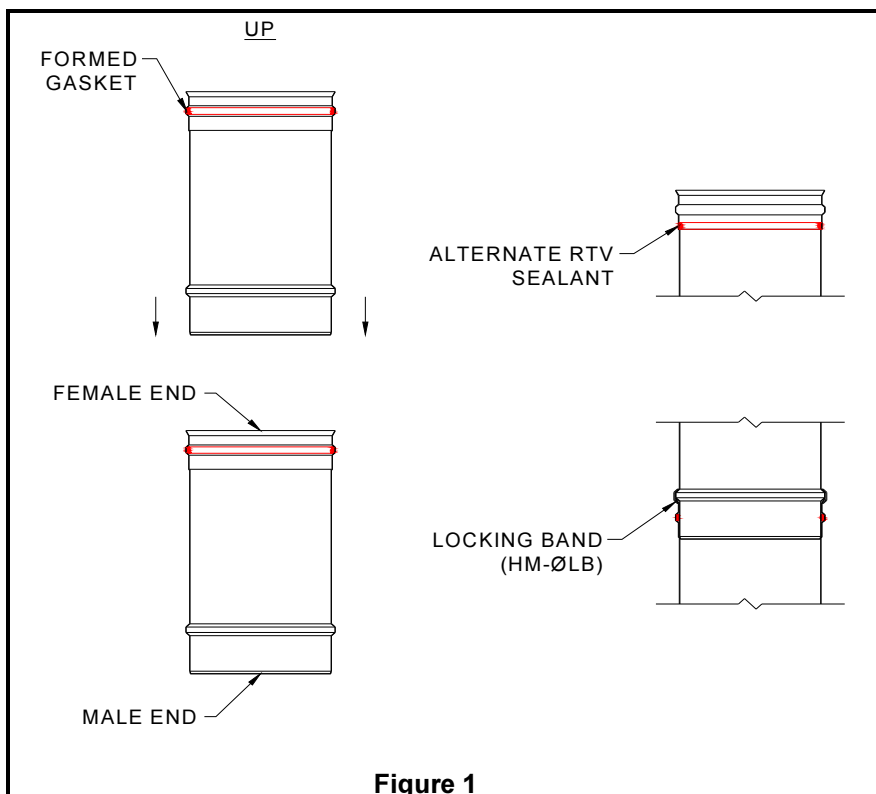

To connect two parts together simply insert the male end of one part into the female end of the adjoining part and press firmly until the bead of the male end connects with the female end (**Figure 1**). Once the parts are firmly joined, secure the joint connection as shown in **Figure 3** and **Figure 4**. A locking band or a band collar comes with every part. You can put a small amount of liquid dish soap on each gasket to make it easier to assemble the vent. Do not use a petroleum-based lubricant.

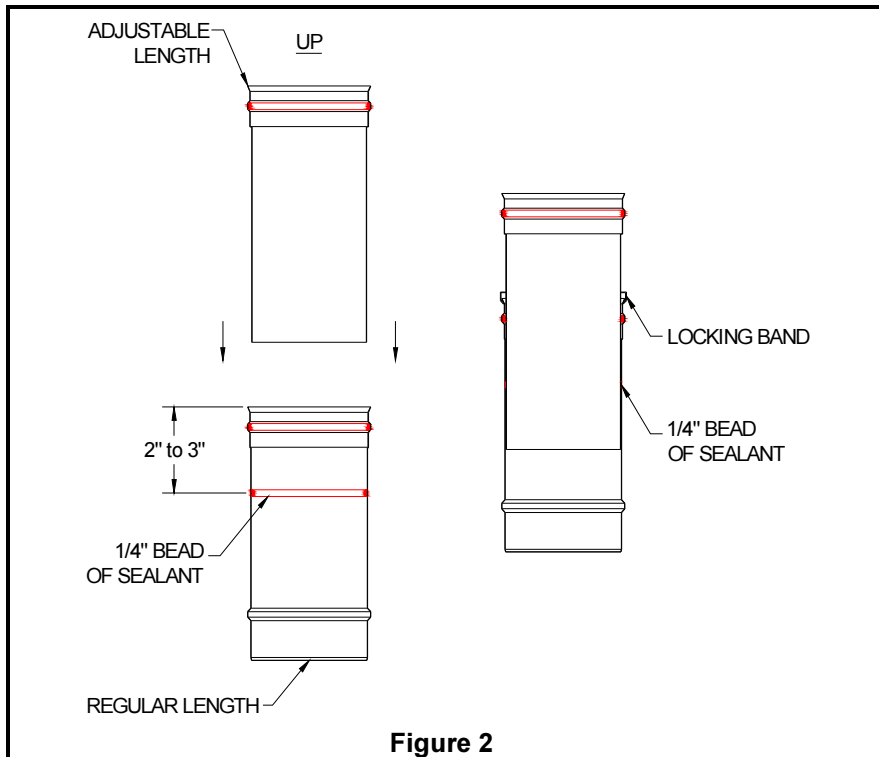

The adjustable length adjusts by sliding inside a regular length or fitting. The adjustment range is from 4 ½” to 9 ½” for the 12” adjustable length and 4 ½” to 22 ½” for the 24” adjustable length. Make sure each joint is clean by removing oil and other contaminants; alcohol has been found suitable to clean the joints. To seal the adjustable length you will first need to apply a ¼” bead of sealant inside the regular length or fitting about 2” to 3” from the female end. Insert the adjustable length inside the female joint by twisting slightly, to ensure even distribution of the sealant. Once you have reached the desired length, install the locking band over the joint as shown in **Figure** . The adjustable length comes with its own locking band.

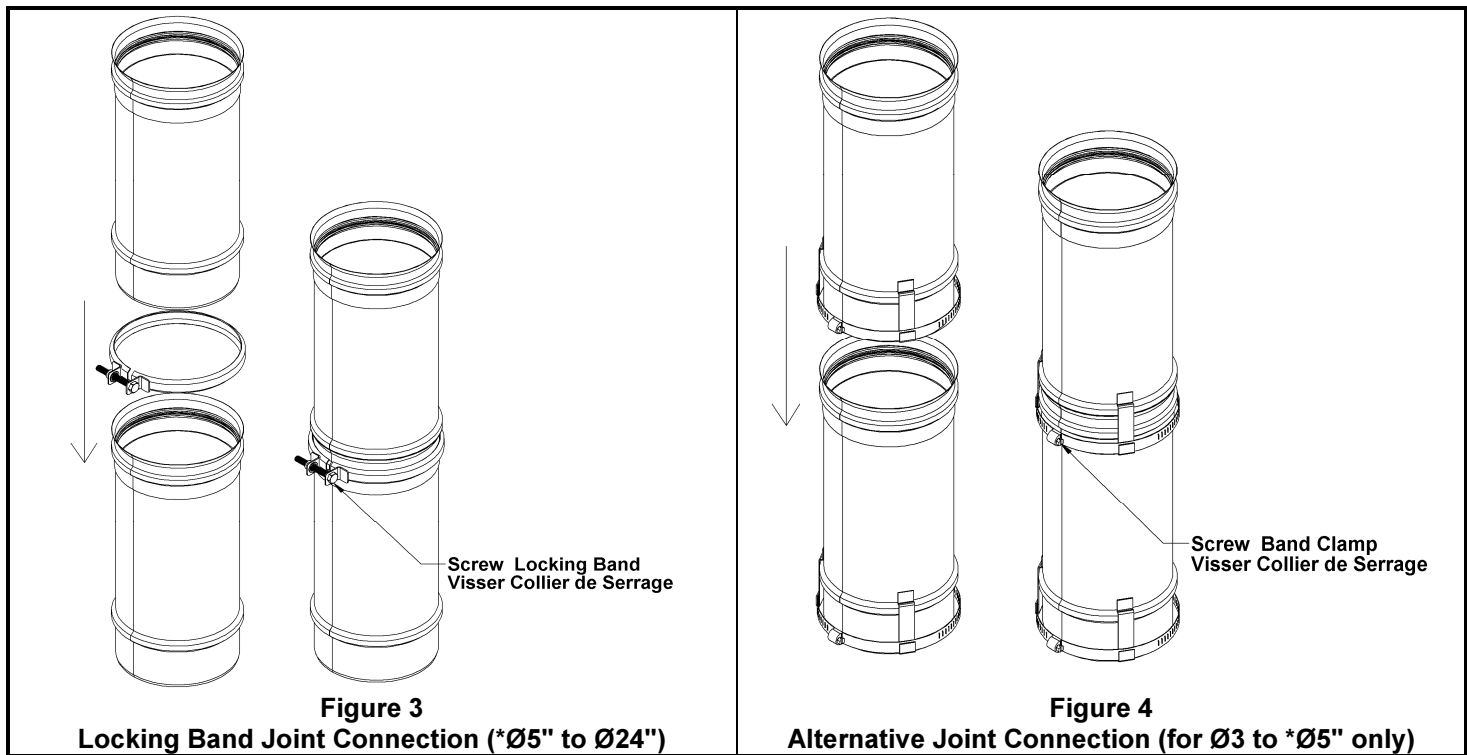

\* Ø5 Chimney Sections may be available with both types of connection.

### RTV sealant (10 oz Cartridge & 3 oz Tube) Coverage

	3"	4"	5"	6"	7"	8"	9"	10"	12"	14"	16"	18"	20"	22"	24"
# of joints (10 oz)	84	63	50	42	36	32	28	25	21	18	16	14	13	12	11
# of joints (3 oz)	25	19	15	13	11	10	9	8	6	6	5	4	4	3	3

- The coverage is about 66’ per 10 oz cartridge and 20’ per 3 oz tube for a ¼” bead.
- Actual coverage may vary.

Note: The Appliance Adapter will most likely also be sealed using the RTV sealant. See the appliance manufacturer instructions for detail.

## Horizontal through the wall installation

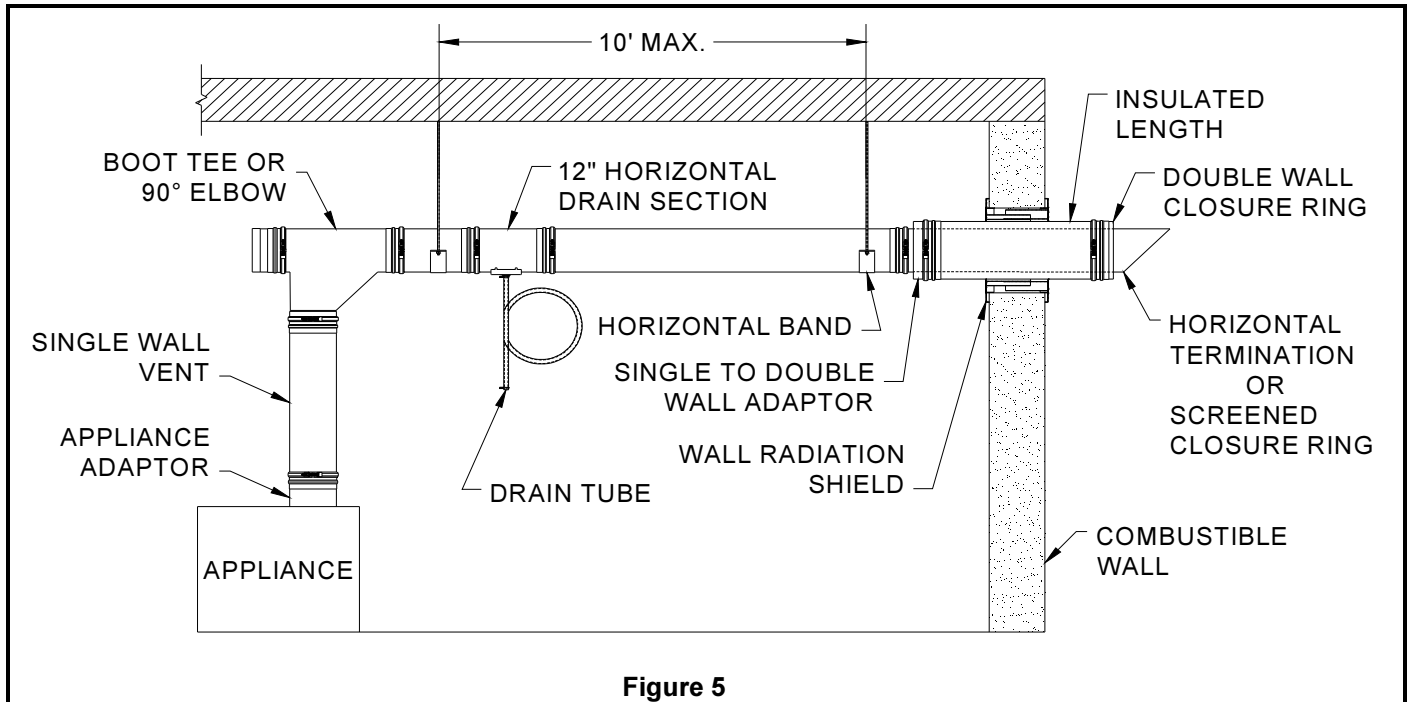
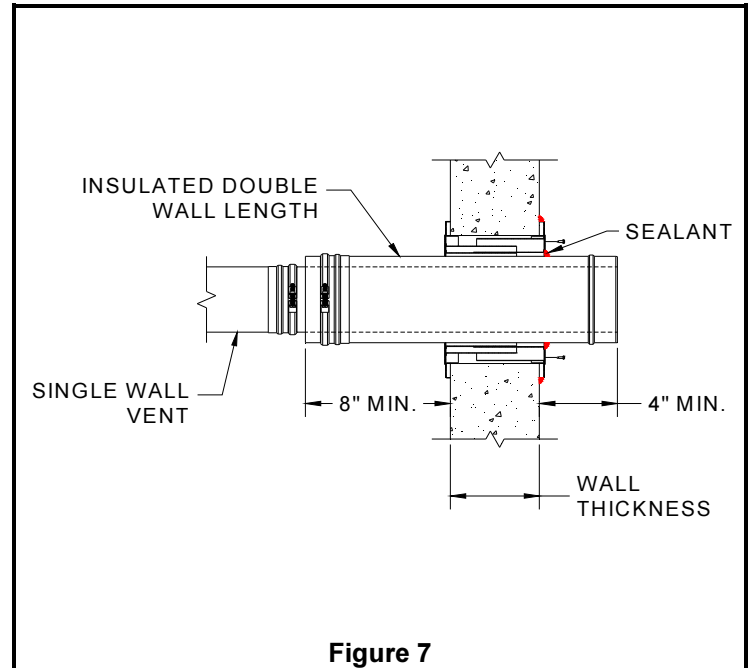
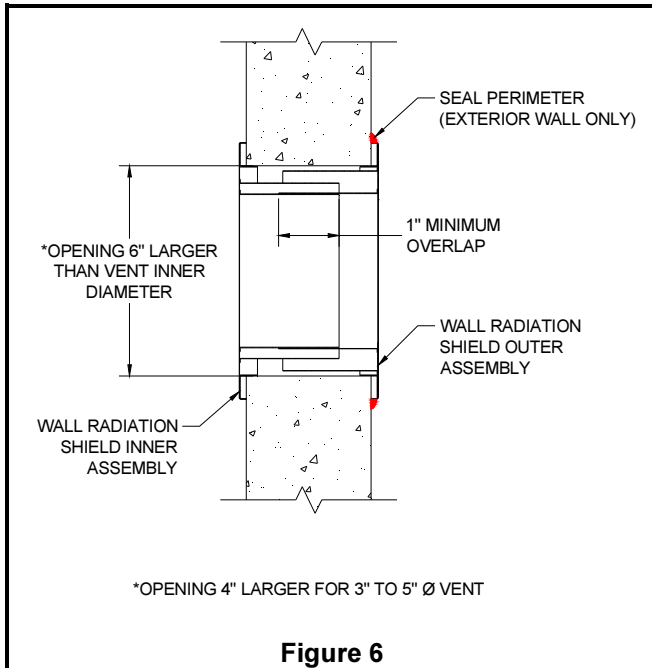

Figure 5

### Requirements:

- The vent system must terminate with a Model VIC termination or with an approved mechanical vent device, or with the appliance manufacturer listed termination.
  - The total continuous distance of the vent system from the appliance flue collar to the termination shall not exceed that specified in the appliance manufacturer's installation instructions. When venting natural draft appliances the termination must be at least 5' above the topmost draft hood. Otherwise a Listed mechanical draft inducing device is required.
  - Termination Location:
    - a) The vent shall terminate at least 3' above any forced air inlet located within 10'.
    - b) The vent shall terminate at least 4' below, 4' horizontally from or 1' above AND 2' horizontally from any door, window or gravity air inlet into any building.
    - c) The vent termination shall be at least 12" above grade or, in geographical areas where snow accumulates, at least 12" above the anticipated snow line.
    - d) Through-the-wall vents for Category II and IV appliances and non-categorized condensing appliances shall not terminate over a public walkway or an area where condensate or vapors could create a nuisance or hazard or could be detrimental to the operation of regulators, relief valves or other equipment.
    - e) The vent termination shall also be at least 8' horizontally from any combustion air intake, located above it.
  - Proper means for draining condensate should be provided. Proper sloping is required when the vent is installed horizontally.
  - The drain fitting should be installed as close to the appliance flue collar as possible.
  - Use non-combustible hanger straps or ICC horizontal bands every 8' to support the vent. 1/4"Ø threaded rod is typically used with ICC Horizontal Band. **Do not puncture the vent system with screws or other fasteners.**
  - The horizontal vent must slope upward toward the termination at least 1/4" per foot and be installed so that all condensate runs back toward the appliance and is not retained in any part of the venting system. Exception: If the system is connected to a positive pressure (Category III or IV) appliance, terminates with a horizontal termination, and has no provision for draining condensation and/or rain water; then the vent must pitch downward toward the termination at a pitch at least 1/4" per foot.
1. Determine the appliance and termination location that agrees with both the codes and appliance manufacturer's requirements.
  2. Cut and frame a square opening in the wall making sure the center of the hole is aligned with the center of the horizontal vent. **The opening must be 6" larger than the vents inner diameter (for 6" to 24" Ø) and 4" larger than the vent inner diameter (3" to 5"Ø).**
  3. Install both parts of the Wall Radiation Shield and screw (or nail) them to the frame (see **Figure 6**). Seal the Wall Radiation Shield perimeter to the exterior wall with caulking to prevent water infiltration.

Note: The Wall Radiation Shield will fit wall thickness from 5 3/4" to 10 1/2". For wall thickness smaller than 5 3/4", cut both sleeves as required. Once installed, an overlap of 1" minimum is necessary.



4. Install the vent starting at the appliance. Make sure to install a Horizontal Band every 10' or after every change in direction of the vent.
5. You will need to install an Insulated Length through the Wall Radiation Shield. The Insulated Length must be at least 12" longer than the wall thickness. Once installed, the Insulated Length must protrude at least 8" from the interior and 4" from the exterior wall surface.
6. Install a Single to Double Wall Adapter on the bottom of the Insulated Length. Position the assembly inside the Wall Radiation Shield and connect the single wall vent to the Single to Double Wall Adapter. If necessary, install an Adjustable Length to connect to the Single to Double Wall Adapter.
7. Screw the two half plates into the pre punched holes on the Wall Radiation Shield exterior plate (see **Figure 7**). Those half plates are supplied with the Wall Radiation Shield.
8. Check the make sure a minimum slope of 1/4" per foot is maintained in the horizontal vent. Seal the Insulated Length's outer casing to the Wall Radiation Shield assembly using high temperature sealant to protect against water infiltration.
9. Install either the Horizontal Termination (miter cut) or the Screened Closure Ring on the Insulated Length.
10. Install the Double Wall Closure Ring to cover the end of the Insulated Length and hold the termination in place.

Note: If you are going through a non-combustible wall (concrete wall) you don't need to install the Wall Radiation Shield and the Insulated Length as long as proper clearances to combustibles are maintained around the single wall vent. A round opening 1" larger than the vent diameter is sufficient to allow the single wall vent to go through the non-combustible wall. Seal the gap around the vent with a Firestop and high temperature sealant.

## Condensate Drains

If an internal condensate drain is not part of the appliance, but one is required per the appliance manufacturer's instruction or local code, install a 12" Horizontal Drain Section in the horizontal vent, as close as possible to the appliance flue collar.

A condensate drain is also required at the bottom of a vertical stack.

When installed, the Horizontal Drain Section drain shall be located on the bottom side of the vent system. A 1/2" diameter Drain Tube is available to direct the condensate to a floor drain. A trap loop must be formed in the drain hose and must be a **diameter that is at least four times the appliance's rated stack pressure in inches of water column or a minimum of 3"**. Secure the loop with a cable tie. Prior to final assembly the trap loop must be 'primed' by pouring a small quantity of water into the drain hose. The same apply to the Boot Tee / Drain Tee Cap on vertical installation.

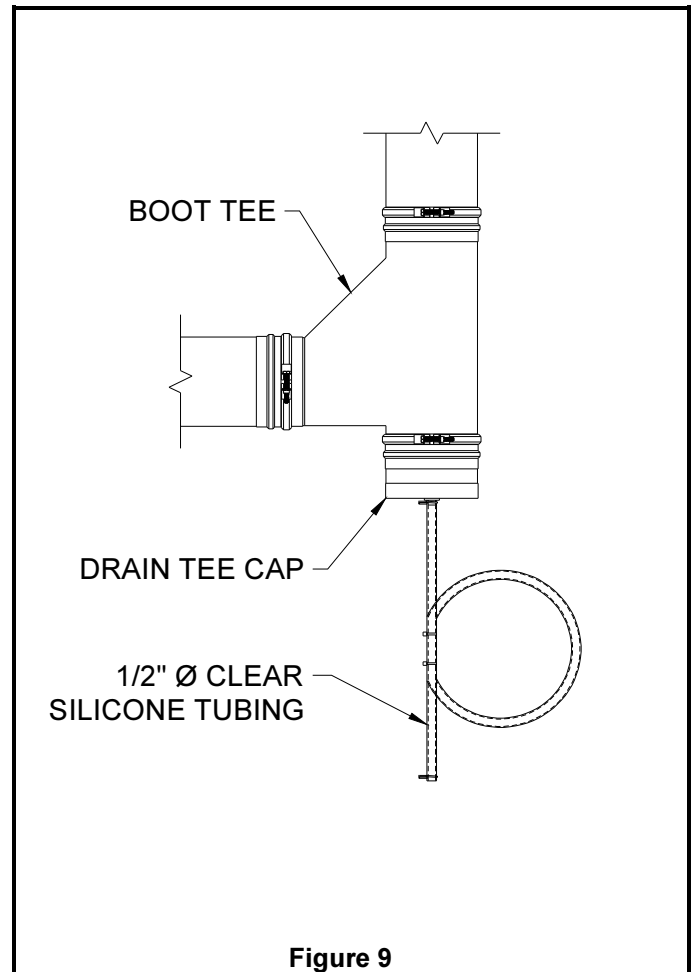
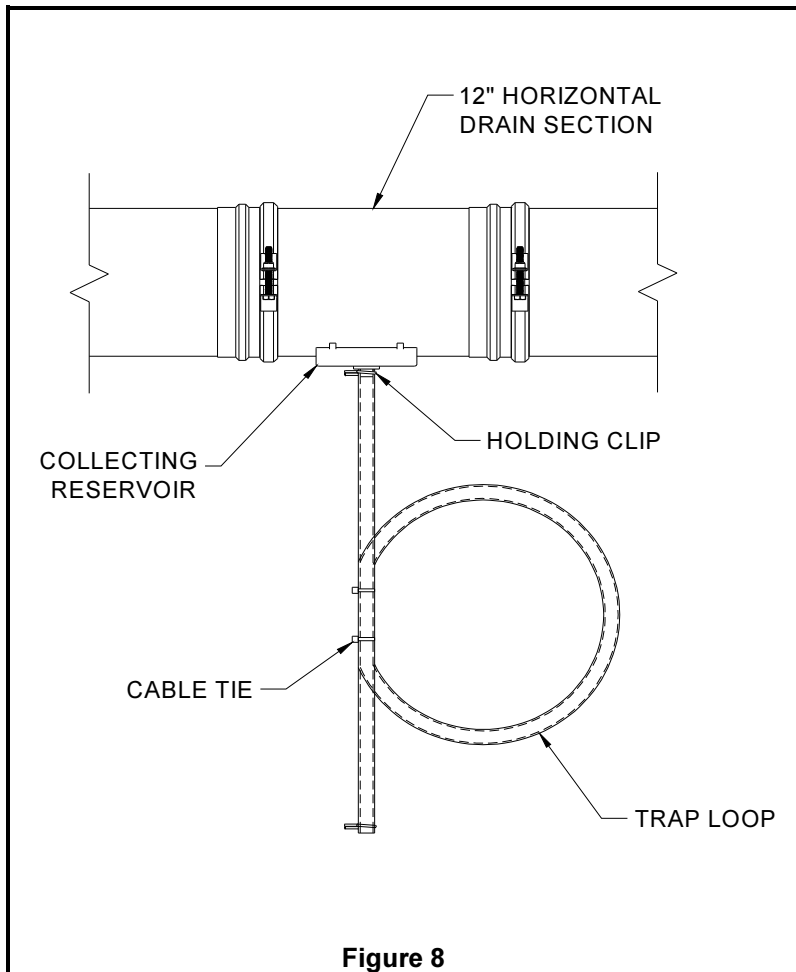



## Vertical interior installation

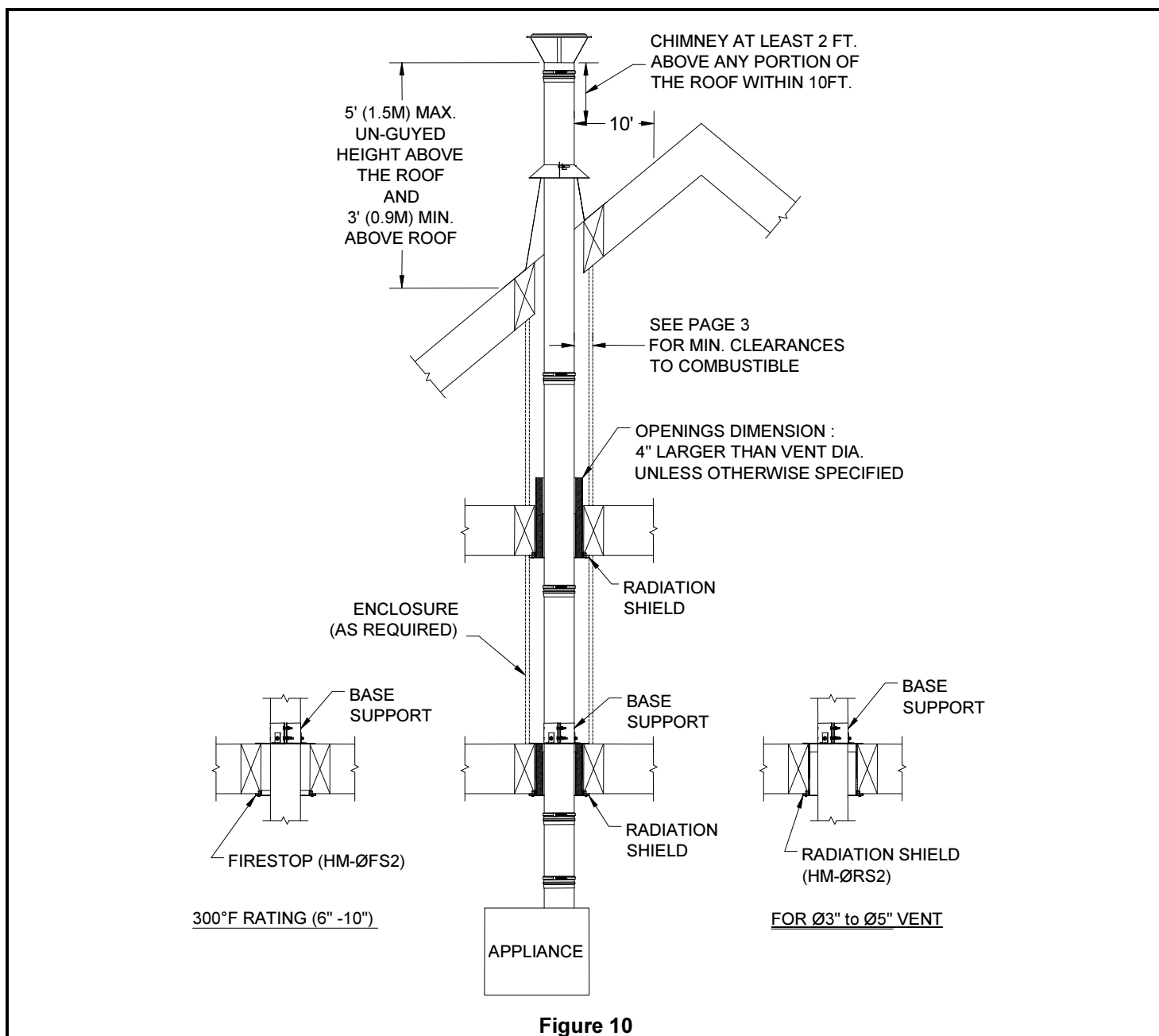

### Requirements:

- Unless installed in a fire rated shaft (enclosure), fire-stopping is required when going through floors and ceilings.
- Vertical termination must terminate no less than 2' above the roof. A Rain Cap or other equivalent termination is required to keep rain or debris out of the vent. Either Model VIC Terminations or approved mechanical vent devices that are specified or provided by the appliance manufacturer are permitted.
- When terminated at a height more than 5' above the roofline, the vent must be stabilized using a Guy Band. For a height of more than 20' contact the factory.

1. Determine the location of the appliance, floor openings and termination that complies with both the codes and appliance manufacturer's requirements.
2. Cut and frame square openings in the floor, ceiling and roof where the vent will pass. **The openings must be 4" larger than the vents inner diameter.** For 3" to 5" diameter installation and for 6" to 10" diameter unenclosed installation with a 300°F rating the openings must be 2" larger than the vent inner diameter.
3. From below, install a Radiation Shield in each floor opening. If you are installing a Base Support on top of the floor you will need to adjust the height of the radiation shield to match the floor thickness. The radiation shield is supplied fully extended. To adjust the radiation shield slide the top tube to the desire height then screw the two sections

together with the self-tapping screws provided (see **Figure 11**). You will need to cut the insulation flush with the top tube. Screw the radiation shield to the framing. For 3" to 5" diameter installation install the Radiation Shield model HM-ØRS2 (this is an un-insulated part). For 6" to 10" diameter unenclosed installation with a 300°F rating install the Firestop model HM-ØFS2 (this is an un-insulated part) instead of the standard Radiation Shield HM-ØRS.

4. Install the vent starting at the appliance. Make sure to install a Horizontal Band every 10' or after every change in direction.
5. After the vent passes through a floor opening screw the two half plates (supplied with Radiation Shield) using the pre-punched holes to the Radiation Shield plate (see **Figure 11**). This will seal the gap around the vent and the Radiation Shield.
6. If you need to support the vent vertically, a Base Support or a Wall Support can be used. The Base Support is installed on top of a floor. The Wall Support can be installed anywhere in the system. Depending on your system layout one support may be better than another. Remember that a support needs to be installed after a vertical deviation.

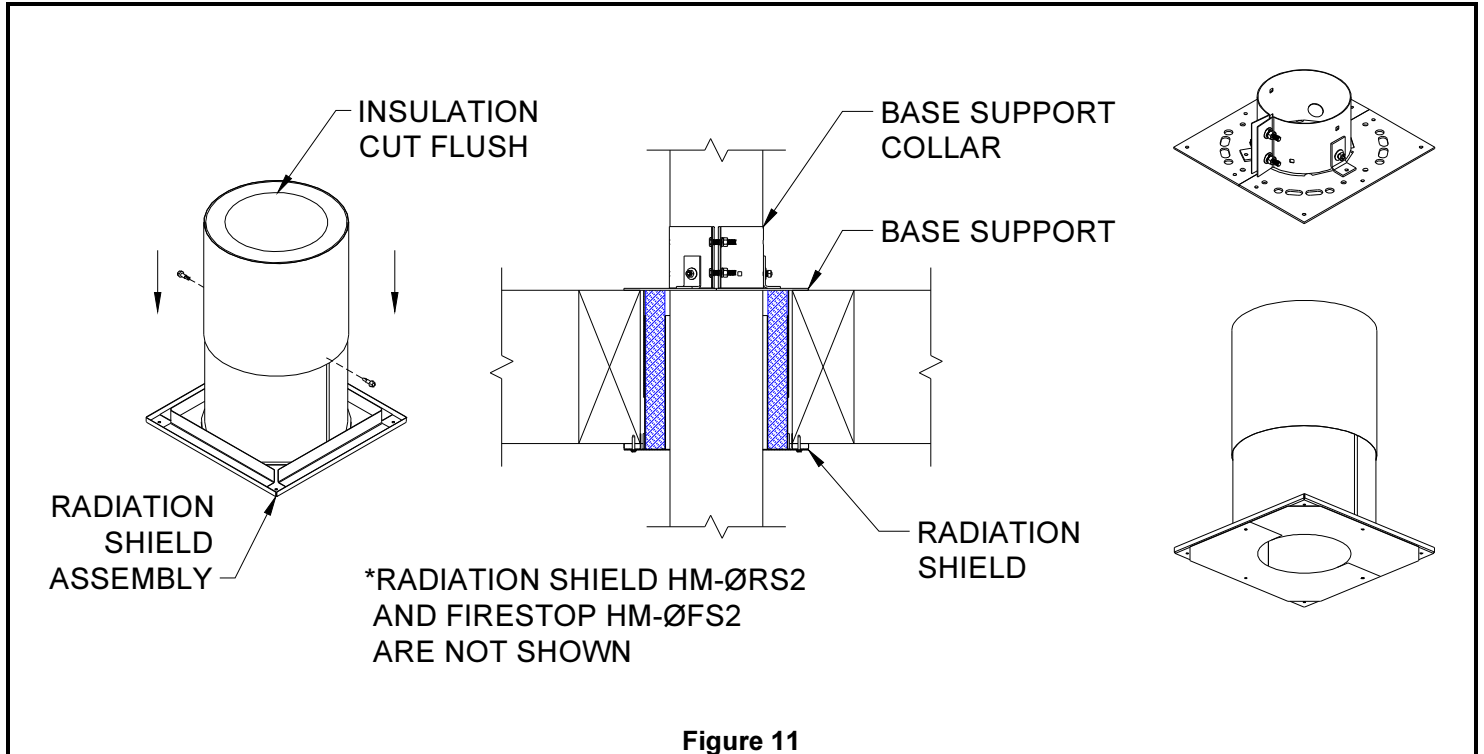

7. Continue adding vent lengths through the roof until the required vent height is reached. The maximum height of un-guyed vent above the roof is 5'. If you have more than 5', install a Guy Band to provide stabilization.
8. Install a Base Support on top of the roof curb. Screw each support collar bracket to the support base using #10-1/2" or bigger sheet metal screws.
9. Install the appropriate roof flashing for your roof pitch. A vented flashing is required for a combustible roof (except for 3" to 5" diameter unenclosed installation). Seal the flashing to the roof with roofing tar or silicone sealant. Place the storm collar over the vent and the flashing. Tighten it in place. Caulk the joint between the vent and storm collar with silicone sealant (see **Figure 12**).

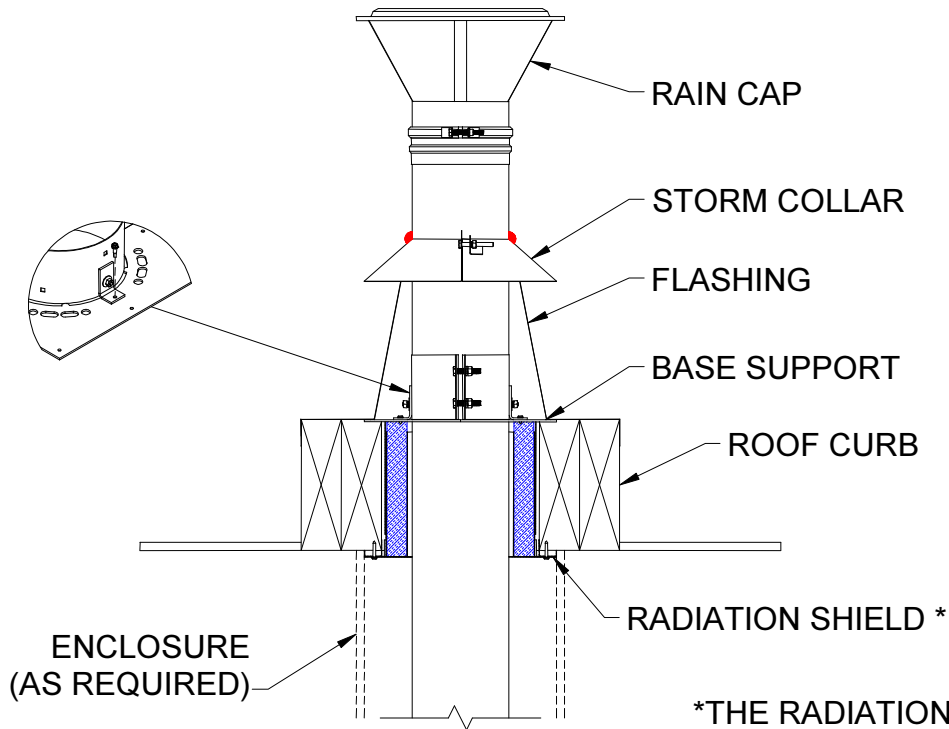

\*THE RADIATION SHIELD IS OPTIONAL EXCEPT FOR Ø3" to Ø5" WHERE A RADIATION SHIELD (HM-ØRS2) OR A ROOF RADIATION SHIELD (HM-ØRRS) MUST BE INSTALLED.

Figure 12

10. Install the rain cap.

## Vertical exterior installation

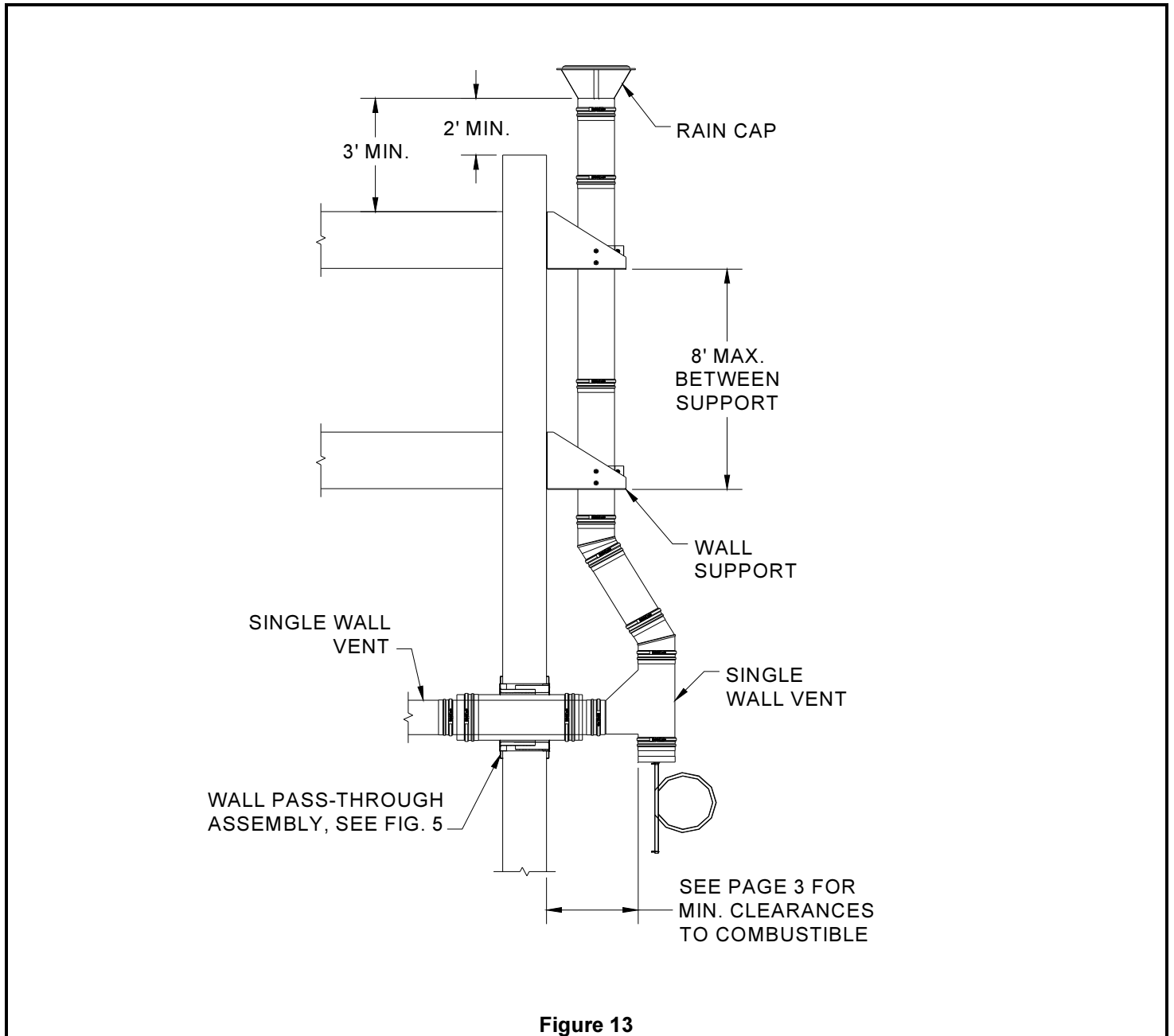

**Figure 13**

### Requirements:

- In cold climates it is not recommended to run single wall vent on the outside of a building. If you have to install a condensing vent on the outside of a building we recommend installing a double wall vent or an insulated double wall vent. If possible, the double wall vent should be fully enclosed in an exterior chase.
1. Follow the instructions for a horizontal through wall installation, but instead of installing the horizontal termination you need to install a Boot Tee and Drain Tee Cap.
  2. A Wall Support should be installed on the first vertical length after the Boot Tee and every 8' after that.
  3. Install the rain cap.

## Base Support

The Base Support is the most common support. It can be used on any floor level or on top of a roof curb. The vent must first go through an opening before the support can be installed. Push the two half plates against the vent and screw them to the framing using five #8-1 ½" screws or another appropriate fastener.

Put the support collar around the vent above the support base and flush with it. Tighten the collar.

If desired you can screw the support collar brackets to the support base using #10-½" or bigger sheet metal screws. This is mandatory when a Base Support is installed on top of a roof curb.

The Base Support maximum load is 30' (12"-24") or 50' (3"-10").

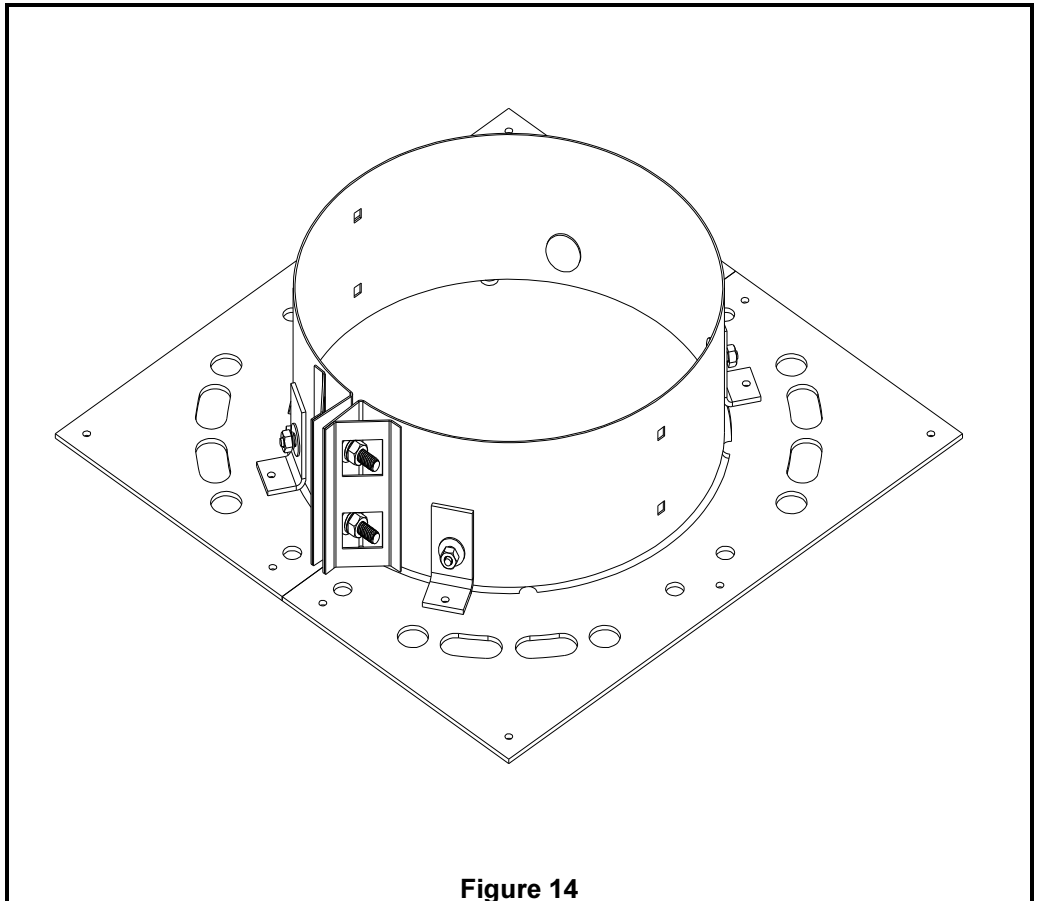

Figure 14

## Wall Support

This support is used on a wall when the vent needs to be supported vertically.

Tighten the support collar around the vent. Make sure to insert the four elevator bolts in the appropriate openings in the collar before placing it around the vent. Using a level, trace a horizontal mark on the wall where you want to install the wall support brackets.

Fasten both brackets to the wall using six #10-2 ½" or larger screws.

The Adjustable Wall Support can also be used to support horizontal run of venting from a ceiling.

The Wall Support maximum load is 30' (12"-24") or 50' (3"-10").

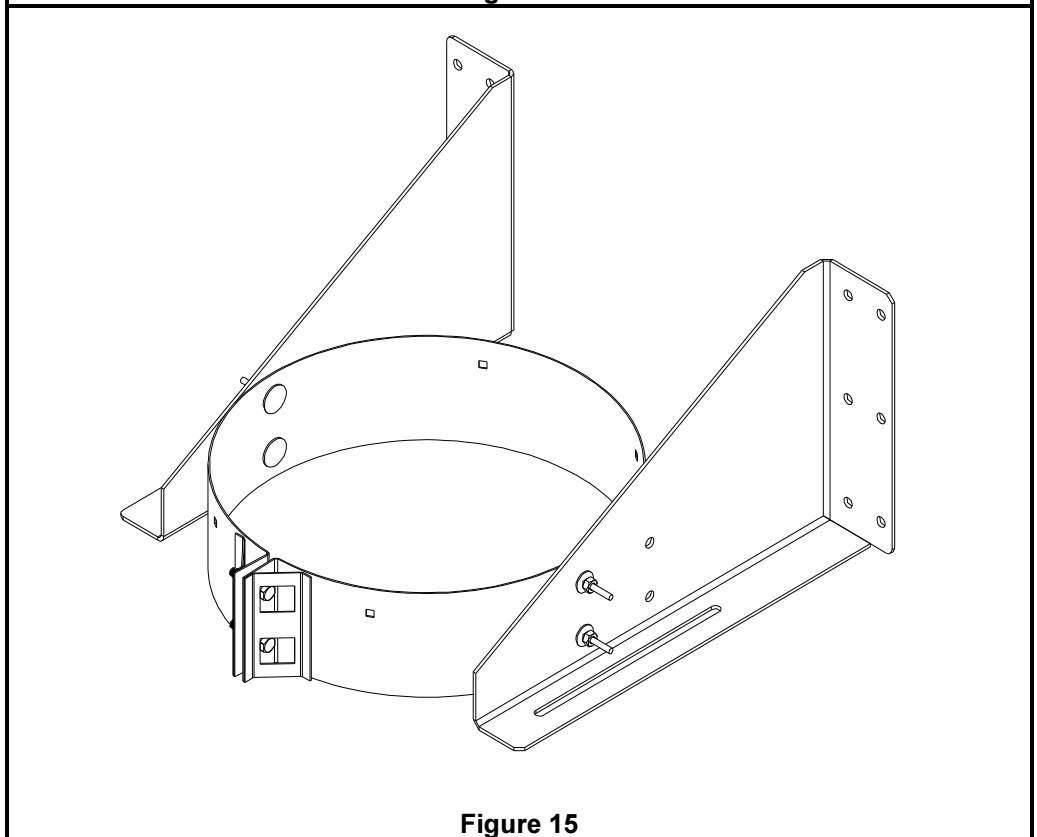

Figure 15

## Horizontal Band

The Horizontal Band is a half band made of 10ga. Galvanized steel designed to support the vent when it travels horizontally.

Typically, 1/4" diameter or larger threaded rod and fasteners are used to attach the band to the ceiling structure (not supplied).

Plumber strapping or any other hanging materials with a rating of 500 lbs. or more can also be used.

Typical configurations are shown in **Figure 16**. To prevent condensation from dripping on the floor never puncture or screw through the vent.

The maximum distance between Horizontal Bands is 10'.

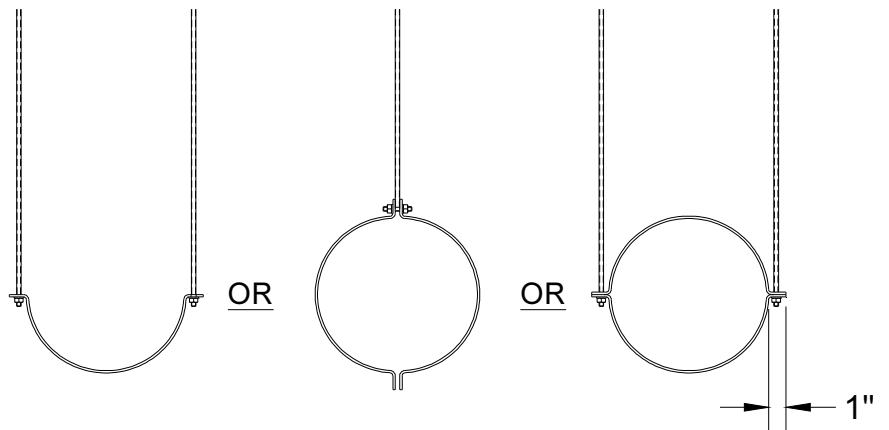

\* DO NOT SCREW THROUGH THE VENT

**Figure 16**

## Guy Band

The Guy Band may be used to secure a vent above the roof. The maximum length of un-guyed vent above the roof is 5'. The maximum length of guyed vent above the roof is 20'. The maximum length of vent between guy bands is 10'. If height greater than 20' is required above the roof, an engineered support system should be installed.

1. Place the band collar around the vent length at the desired location. Tighten the collar.

2. Attach guy wires to the band and to the roof or ceiling using adequate attachments (not supplied). Tighten the guy wires until the vent is properly located and secure.

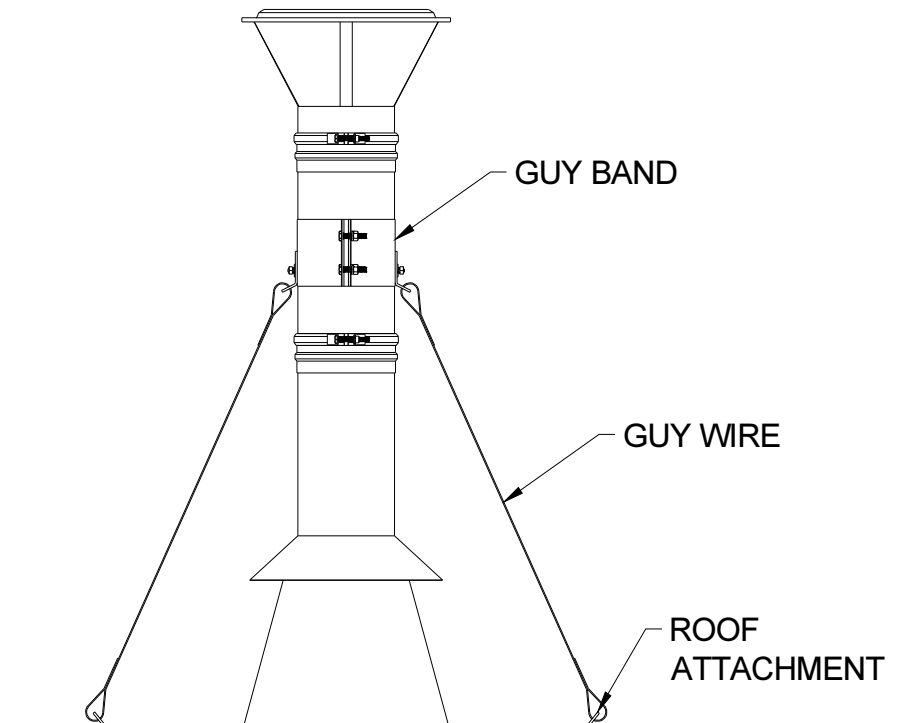

**Figure 17**

## Horizontal Termination location

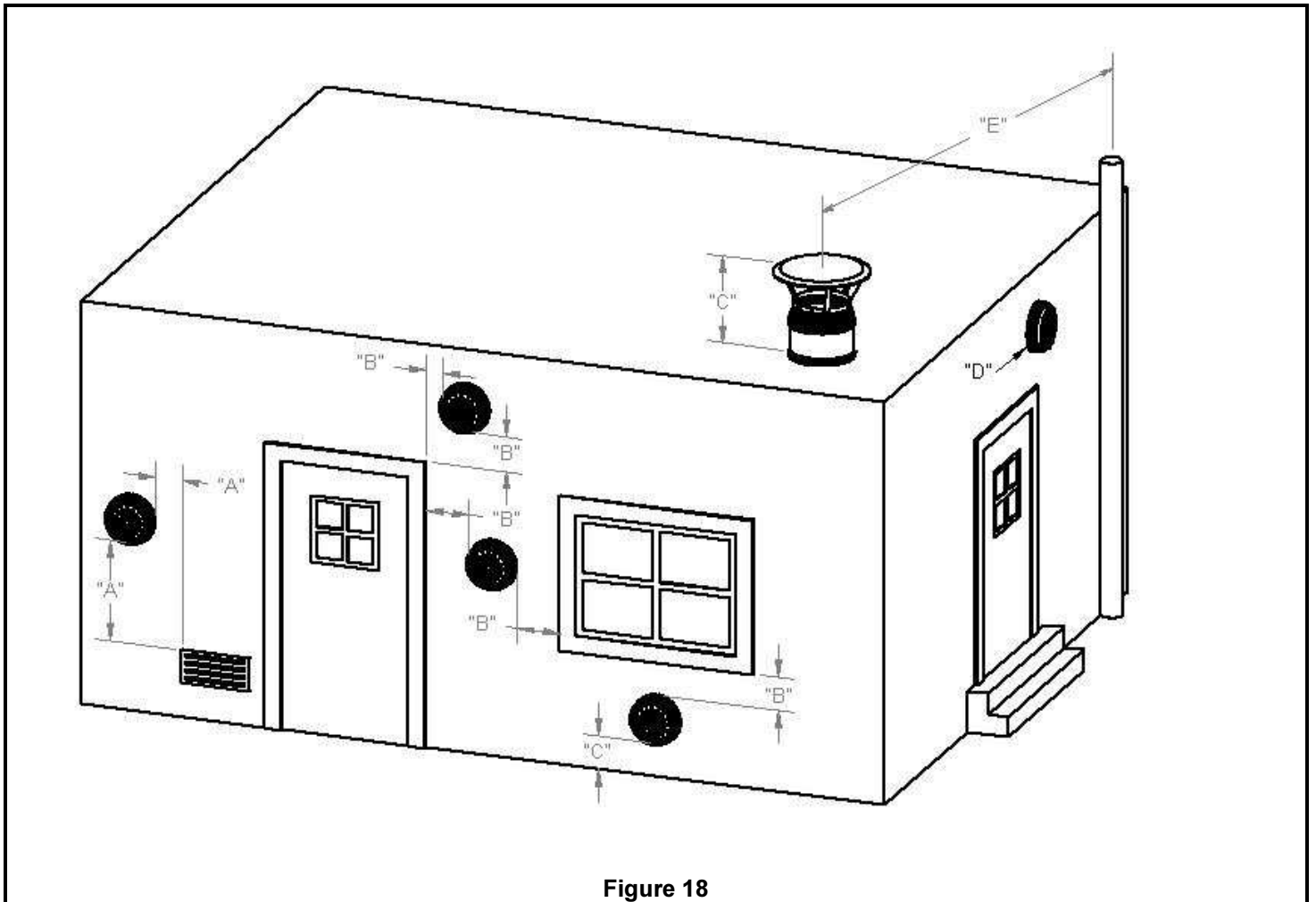

Figure 18

Termination Location:

- The vent shall terminate at least 3' above any forced air inlet located within 10' in any direction.
- The vent shall terminate at least 4' below, 4' horizontally from or 1' above AND 3' horizontally from any door, window or gravity air inlet into any building.
- The vent termination shall be at least 12" above grade or, in geographical areas where snow accumulates, at least 12" above the anticipated snow line.
- Through-the-wall vents for Category II and IV appliances and non-categorized condensing appliances shall not terminate over a public walkway or an area where condensate or vapors could create a nuisance or hazard or could be detrimental to the operation of regulators, relief valves or other equipment.
- The vent termination shall also be at least 8' horizontally from any combustion air intake located above it.

## Model VIC Single Wall - Parts List

Component Name	AL29-4C	444	Supplementary Details
<b>Lengths</b>			
48" Length	HC-ØL4-F	HC-ØL4-E	
36" Length	HC-ØL3-F	HC-ØL3-E	
24" Length	HC-ØL2-F	HC-ØL2-E	
12" Length	HC-ØL1-F	HC-ØL1-E	
6" Length	HC-ØL6-F	HC-ØL6-E	
24" Adjustable Length	HC-ØLA2-F	HC-ØLA2-E	
12" Adjustable Length	HC-ØLA1-F	HC-ØLA1-E	
12" Horizontal Drain Section	HC-ØLHD-F	HC-ØLHD-E	
12" Inline Test Port Section	HC-ØIPS-F	HC-ØIPS-E	
Ø <sub>1</sub> To Ø <sub>2</sub> Increaser	HM-Ø <sub>1</sub>  Ø <sub>2</sub> -F	HM-Ø <sub>1</sub>  Ø <sub>2</sub> -E	
<b>Elbows &amp; Tees</b>			
15° Elbow	HE-ØE15-F	HE-ØE15-E	
30° Elbow	HE-ØE30-F	HE-ØE30-E	
45° Elbow	HE-ØE45-F	HE-ØE45-E	
90° Elbow	HE-ØE90-F	HE-ØE90-E	
90° Boot Tee	HE-ØBT-F	HE-ØBT-E	Not available in Ø3" and Ø4"
90° Tee	HE-ØT-F	HE-ØT-E	
Regular Tee Cap	HE-ØTC-F	HE-ØTC-E	
Drain Tee Cap	HE-ØTD-F	HE-ØTD-E	
<b>Supports &amp; Firestops</b>			
Base Support		HM-ØBS	
Wall Support		HM-ØWS	
Horizontal Band		HM-ØHB	
Firestop		HM-ØFS	
Firestop		HM-ØFS2	6" to 10" Ø, 300°F rating only
Radiation Shield		HM-ØRS	6" to 24" Ø
Radiation Shield		HM-ØRS2	3" to 5" Ø
Roof Radiation Shield		HM-ØRRS	3" to 5" Ø
Wall Radiation Shield		HM-ØWRS	
<b>Terminations</b>			
Rain Cap	HM-ØRC-F	HM-ØRC-E	
Horizontal Termination (Miter Cut)	HM-ØMC-F	HM-ØMC-E	
Screened Closure Ring	HM-ØSCR-F	HM-ØSCR-E	
Excit Cone	HM-ØEC-F	HM-ØEC-E	
<b>Flashing and collar</b>			
Flat Flashing		HF-ØF	
Flashing 1/12 – 7/12		HF-ØFA	
Flashing 8/12 – 12/12		HF-ØFB	
Vented Flat Flashing		HF-ØVF	
Vented Flashing 1/12 – 7/12		HF-ØVFA	
Vented Flashing 8/12 – 12/12		HF-ØVFB	
Storm Collar		HM-ØSC	
<b>Accessories</b>			
Locking Band		HM-ØLB	
Guy Band		HM-ØGB	
Single to Double Wall Adapter	HM-ØSDA-FD	HM-ØSDA-ED	AL29-4C/SS430 OR SS444/SS430



## **WARRANTY**

### **LIMITED 10 YEAR WARRANTY**

ICC warrants its Model VIC vent to be free of defects in materials and workmanship for a period of ten years from the date of purchase from ICC. This ten year warranty will only apply to systems which meet the following criteria:

The complete system must have been designed and sized by ICC engineers and all pertinent design and operating parameters of the system must have been accurately represented to ICC.

The entire vent system, including breeching as required, must have been supplied by ICC. Systems partially supplied by ICC do not qualify under this warranty.

The system must be installed in accordance with the installation instructions provided.

Proper precautions have been taken to ensure that the combustion air is free of solvent or refrigerant vapors as well as any compounds which may cause acid condensates to form.

All exposed galvalume, galvanized, or steel surfaces must be protected at all times by a minimum of one base coat of primer and one finish coat of heat resistant and corrosion resistant paint. Stainless steel surfaces need not be primed or painted.

### **WARRANTY STIPULATIONS**

Remedies under the one year and ten year warranties are strictly limited to repairing or replacing, at ICC's option, any components which are determined by ICC to be defective. The warranties do not cover any labor costs or freight charges. Any parts returned to ICC under terms of the warranties must be returned freight prepaid.

ICC shall not be liable for incidental or consequential damages of any kind or for any damages resulting in whole or in part from misuse, improper installation, or inadequate maintenance of the system. In no event shall ICC be liable for any costs of installation, removal or replacement. No agent is authorized to make any modifications to this warranty or offer any additional warranties of any kind on behalf of ICC.

In all cases the system must be examined by a factory authorized representative in order to determine liability under this warranty.